

SERVICE MANUAL

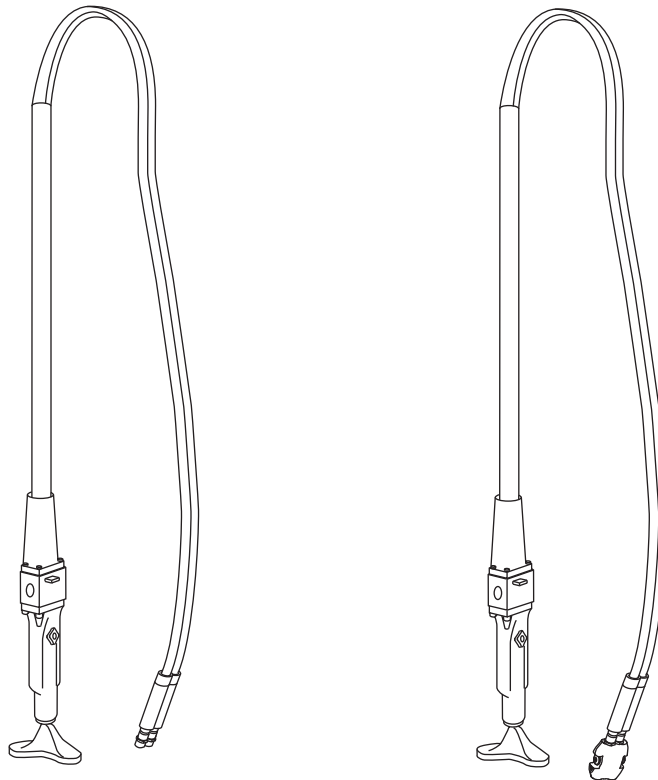

GREENLEE[®]
UTILITY
A Textron Company



H4802, H4802-1, and H4802-6 Pole Tampers

Serial Codes FKA, FKF, FKM, FZP, FZR, and FZT



Read and understand all of the instructions and safety information in this manual before operating or servicing this tool.

Register this product at www.greenlee.com

Table of Contents

Safety	2
Purpose of this Manual	2
Other Publications	2
Important Safety Information	3-4
Disassembly	5
Inspection	5
Assembly	6
Illustration and Parts List	7-9

Safety

Safety is essential in the use and maintenance of Greenlee tools and equipment. This manual and any markings on the tool provide information for avoiding hazards and unsafe practices related to the use of this tool. Observe all of the safety information provided.

Purpose of this Manual

This manual is intended to familiarize all personnel with the safe service procedures for the following Greenlee Utility tools:

H4802	Serial Codes FKA and FZP
H4802-1	Serial Codes FKM and FZR
H4802-6	Serial Codes FKF and FZT

Keep this manual available to all personnel.

Replacement manuals are available upon request at no charge at www.greenlee.com.

Other Publications

Instruction Manual: Publication 99930196

SAE Standard J1273 (Hose and Hose Assemblies):
Publication 99930323

All specifications are nominal and may change as design improvements occur. Greenlee Textron Inc. shall not be liable for damages resulting from misapplication or misuse of its products. Loctite and 242 are registered trademarks of Loctite Corporation.

KEEP THIS MANUAL

IMPORTANT SAFETY INFORMATION



**SAFETY
ALERT
SYMBOL**

This symbol is used to call your attention to hazards or unsafe practices which could result in an injury or property damage. The signal word, defined below, indicates the severity of the hazard. The message after the signal word provides information for preventing or avoiding the hazard.

⚠ DANGER

Immediate hazards which, if not avoided, **WILL** result in severe injury or death.

⚠ WARNING

Hazards which, if not avoided, **COULD** result in severe injury or death.

⚠ CAUTION

Hazards or unsafe practices which, if not avoided, **MAY** result in injury or property damage.



⚠ WARNING

Skin injection hazard:

Oil under pressure easily punctures skin, causing serious injury, gangrene, or death. If you are injured by escaping oil, seek medical attention immediately.

- Do not use hands to check for leaks.
- Do not hold hose or couplers while the hydraulic system is pressurized.
- Depressurize the hydraulic system before servicing.

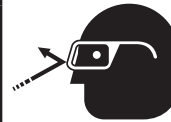

⚠ WARNING

Wear eye protection when operating or servicing this tool.

Failure to wear eye protection could result in serious eye injury from flying debris or hydraulic oil.

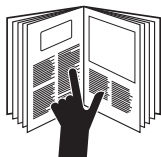

⚠ WARNING

Read and understand all of the instructions and safety information in this manual before operating or servicing this tool. Refer also to the Instruction Manual, which is listed under "Other Publications."

Failure to observe this warning could result in severe injury or death.

⚠ WARNING

Do not exceed the maximum hydraulic flow, pressure relief, or back pressure listed in the Specifications and Parts manual.

Failure to observe this warning could result in severe injury or death.

⚠ WARNING

Do not disconnect tool, hoses, or fittings while the power source is running or if the hydraulic fluid is hot. Hot hydraulic fluid can cause serious burns.

IMPORTANT SAFETY INFORMATION**⚠ WARNING**

Do not reverse hydraulic flow. Operation with hydraulic flow reversed can cause tool malfunction. Connect the pressure (supply) hose and tank (return) hose to the proper ports.

Failure to observe this warning could result in severe injury or death.

⚠ WARNING

Do not change accessories, inspect, adjust, or clean tool when it is connected to a power source. Accidental startup can result in serious injury.

Failure to observe this warning could result in severe injury or death.

⚠ CAUTION

Hydraulic oil can cause skin irritation.

- Handle the tool and hoses with care to prevent skin contact with hydraulic oil.
- In case of accidental skin contact with hydraulic oil, wash the affected area immediately to remove the oil.

Failure to observe these precautions may result in injury.

IMPORTANT

Procedure for connecting or disconnecting hydraulic hoses, fittings, or components:

1. Move the flow lever on the hydraulic power source to the off position.
2. Stop the hydraulic power source.
3. Follow the sequence under “Hose Connections” in the Operation Manual to prevent pressure buildup. In case some pressure has built up, loosen hoses, fittings, or components slowly.

Disassembly

Complete disassembly of the tool is not recommended. If a complete overhaul is necessary, return the tool to your nearest Greenlee Utility Authorized Service Center.

The disassembly procedure is divided into sections of the tool. Disassemble only the section(s) necessary to complete the repair.

Disassemble the tool on a flat, clean surface. Take care not to lose or damage any parts that may fall free during disassembly.

Tube

1. Remove the screws (27) that fasten the adapter (26) to the tube (25). Remove the hose clamps.
2. Remove the cap screws (28) that secure the tube (25) to the valve body (10).
3. Slide the tube away from the valve body to expose the hose connections. Mark the end of the pressure hose for correct assembly. Disconnect the hoses (29) from the adapters (24) on the tamper unit. Slide the hoses out of the tube.

Control Valve Components

1. Disconnect the hoses (29) from the valve body (32). If necessary, remove the adapters (30, 31).
2. Remove the cap screw (37) and button (36) from one end of the control spool (34). Slide the control spool out of the opposite end of the valve body.
3. Remove the O-rings (35) from the valve body (32). Remove the other machine screw and button from the opposite end of the control spool.

Tamper Unit

1. Scribe a line across the valve body (10) and tamper body (1) for correct assembly.
2. Loosen the cap screw (23) that fastens the foot (21) to the ram. Loosen it so that it protrudes far enough from the bottom surface of the tamper foot to be struck with a hammer or pressed against with a hydraulic press.
3. Slide the ram (2) out of the tamper body as far as it will go. See 3a to remove the tamper foot manually. See 3b to remove the tamper foot with a hydraulic press.
 - 3a. Taking care not to damage the ram surface, secure the tamper foot in a vise with the bottom of the foot upward. Set a block of wood on the cap screw (23) and strike the block with a heavy mallet until the tamper foot is released from the ram. Remove the cap screw (23) and washer (22). Remove the tamper foot.
 - 3b. Taking care not to damage the ram surface, secure the tamper foot in a hydraulic press and apply force to the cap screw (23) until the tamper foot is released from the ram. Remove the cap screw and washer (22). Remove the tamper foot.
4. Remove the cap screws (18) that secure the valve body (10) to the tamper body (1). Remove the valve body from the tamper body. Remove the O-rings (16, 17) from the valve body.
5. Remove the plugs (11, 14) from the valve body. Remove the spring (13), stop (12), and spool (9) from the valve body. Remove the O-ring (15) from the plug. If necessary, remove the adapters (24).
6. Unscrew the packing nut (3) from the bottom end of the tamper body (1). Remove the rod wiper (7), U-cup seals (4, 5) and O-ring (6) from the packing nut.
7. Remove the ram (2) and shaft (8) from the tamper body.

Inspection

Clean all parts with solvent and dry them thoroughly. Inspect each component. Replace any component that shows wear or damage.

Assembly

Refer to the illustration and parts list for correct orientation and placement of parts.

Replace any O-rings, V-rings, seals, and gaskets on parts that have been disassembled. Apply hydraulic fluid or O-ring lubricant to all O-rings and all metal surfaces which they must slide over. When installing an O-ring which must slide over sharp surfaces, use a rolling motion and be careful not to damage the O-ring.

Wherever the assembly results in metal-to-metal contact, coat the surfaces with hydraulic fluid or O-ring lubricant.

Tamper Unit

1. Assemble the O-ring (6), U-cup seals (4, 5), and rod wiper (7) to the packing nut (3).
2. Install the ram (2) into the tamper body (1).
3. Thread and tighten the packing nut into the end of the tamper body.
4. Install the shaft (8) into the center bore in the tamper body, as shown.
5. Install the plug (11) into the valve body (10).
6. Install the O-ring (15) into the plug (14).
7. Slide the spool (9) into the valve body, as shown. Set the stop (12), flanged end first, into the spool. Install the spring (13) over the stop and secure with the plug (14).
8. Install the O-rings (16, 17) into their appropriate bores in the bottom of the valve body (10).
9. Set the valve body on top of the tamper body (1) and align the scribed marks that were made during disassembly. Fasten the valve body with four cap screws (18).
10. Install the adapters (24) into the ports on the top of the valve body.
11. Install the tamper foot (21) onto the end of the ram. Install the cap screw (23) with washer (22) and tighten the cap screw securely.

Tube

1. Refer to the parts illustration and the markings on the pressure hose for appropriate hose connection. Thread the hoses onto the adapters (24) in the top of the valve body.
2. Slide the tube over the hoses. Secure the tube to the valve body with four cap screws (28).
3. Apply a thread sealant, such as Loctite® 242® Threadlocker, to the threads of the screws (27). Follow the manufacturer's instructions for curing. Slide both hose clamps (26) into the end of the tube (25) and secure with four screws (27).

Control Valve Components

1. Install the adapters (30, 31) into the valve body (32).
2. Refer to the parts illustration and the markings on the pressure hose for appropriate hose connection. Connect the hoses to the adapters.
3. Slide the control spool (34) into the valve body (32). Install one O-ring (35) into the valve body. Slide the control spool through the valve body over the installed O-ring so that it protrudes just far enough to install the other O-ring (35). Then push the spool (34) over the other installed O-ring (35).
4. Install the buttons (36) onto each end of the control spool. Apply a thread sealant, such as Loctite 242 Threadlocker, to the threads of the machine screws (37). Follow the manufacturer's instructions for curing. Install the machine screws and torque to 3.5 Nm (31 in-lb).

Illustration

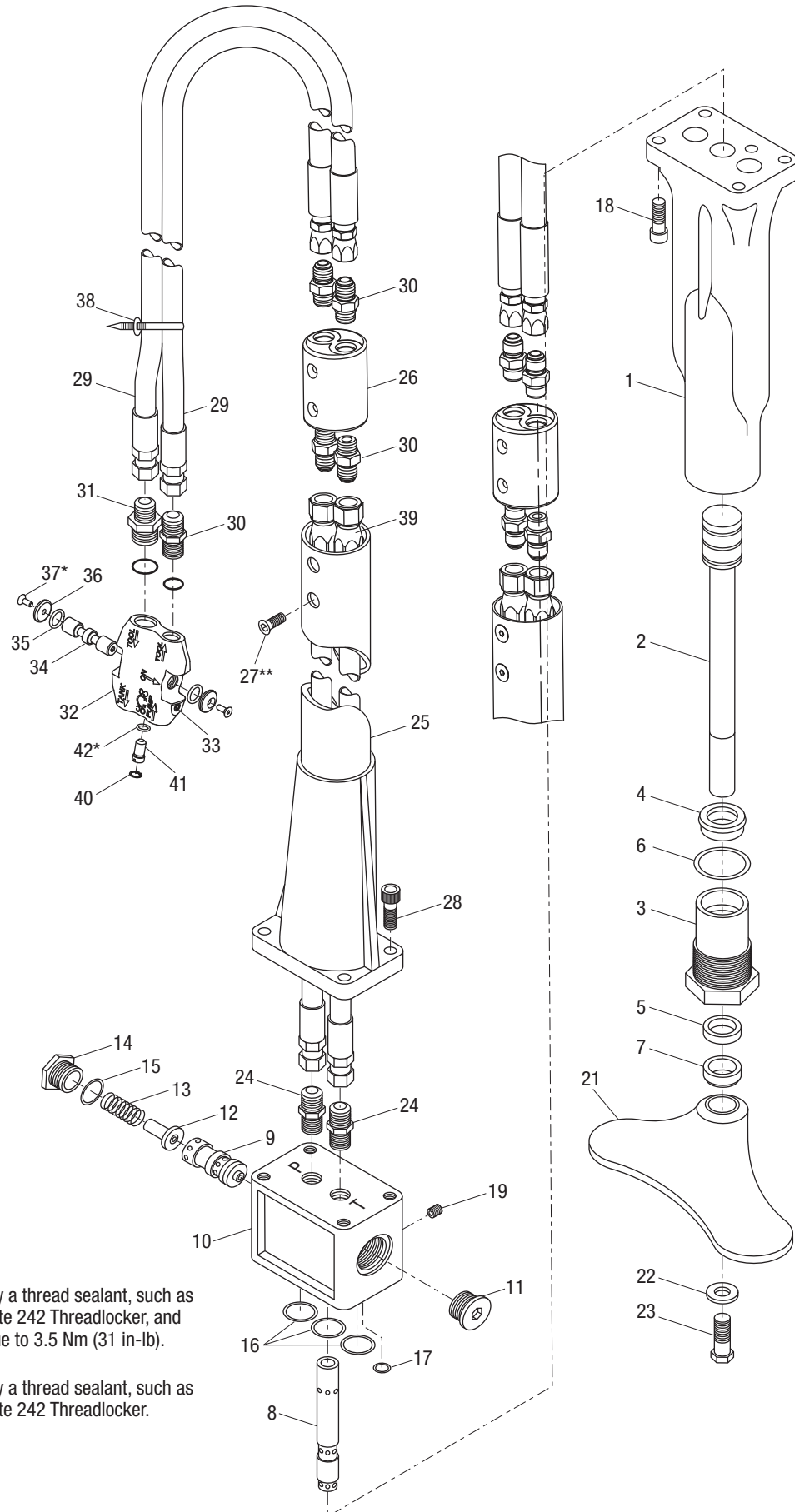

* Apply a thread sealant, such as Loctite 242 Threadlocker, and torque to 3.5 Nm (31 in-lb).

** Apply a thread sealant, such as Loctite 242 Threadlocker.

Parts List

Key	UPC No. 78-3310-	Part No.	Description	Qty
1	40293	50402932	Body, tamper	1
2	40180	50401803	Ram.....	1
3	40377	50403771	Gland, packing (includes items 4-7).....	1
4*			Seal, U-cup, .750 x 1.250 x .375	1
5*			Seal, U-cup, .750 x 1.000 x .250	1
6*			O-ring, 1.475 x 1.711 x .118-90	1
7*			Wiper, rod, .750 x 1.125 x .281	1
8	40295	50402952	Shaft.....	1
9	40297	50402971	Spool.....	1
10	40296	50402961	Body, valve.....	1
11	42072	50420722	Plug, 7/8-14 UNF SAE O-ring boss, socket head, steel	1
12	40298	50402981	Stop, spool	1
13	40299	50402991	Spring, compression, .330 x .500 x 1.250	1
14	40300	50403005	Plug, 7/8-14 UNF SAE O-ring boss, hex head.....	1
15*			O-ring, .755 x .949 x .097-90	1
16*			O-ring, .750 x .937 x .094-70	3
17*			O-ring, .375 x .500 x .062-70	1
18			Screw, cap, 5/16-18 x 1.000 socket head.....	4
21	40301	50403014	Foot, tamper	1
22			Washer, flat, .375 x .875 x .075.....	1
23			Screw, cap, 5/16-24 x 1.250 hex head.....	1
24	41341	50413413	Adapter, 1/4 M NPT x 9/16-18 M JIC (H4802, H4802-1, and H4802-6)	2
25	49536	50495364	Tube, handle (H4802 and H4802-6).....	1
	40358	50403582	Tube, handle (H4802-1).....	1
26	48303	50483030	Adapter	1
27			Screw, machine, 1/4-20 x .50 oval head (H4802 serial codes FZP and FKA03499 and below, H4802-1 serial codes FZR and FKM00019 and below, H4802-6 serial codes FZT and FKF01499 and below	4
			Screw, cap, 1/4-20 x .75 flat head (H4802 serial code FKA03500 and above, H4802-1 serial code FKM00020 and above, and H4802-6 serial code FKF01500 and above)	4
28			Screw, cap, 5/16-18 x 1.000 socket head.....	4
29	48369	50483692	Hose, 3/8 x 56 with 9/16-18 JIC swivel at both ends	2
30	41413	50414133	Adapter, pipe, 9/16-18 UNF SAE O-ring boss x 9/16-18 M JIC (H4802 and H4802-1)	5
			Adapter, pipe, 9/16-18 UNF SAE O-ring boss x 9/16-18 M JIC (H4802-6)	4
31	41422	50414223	Adapter, pipe, 9/16-18 M JIC x 3/4-16 UNF SAE O-ring boss (H4802 and H4802-1)	1
32			Valve body, remote ON/OFF (H4802 and H4802-1).....	1

Parts List (cont'd)

Key	UPC No. 78-3310-	Part No.	Description	Qty
33			Plug, pipe, 1/16 M NPT (H4802 and H4802-1).....	1
34			Spool (H4802 and H4802-1).....	1
35*			O-ring, .562 x .750 x .093 (2-113) (H4802 and H4802-1)	2
36			Button, spool end (H4802 and H4802-1).....	2
37			Screw, cap, #10-24 x .500 flat head (H4802 and H4802-1)....	2
38	41587	50415870	Ty, plastic	4
39	40400	50404004	Hose, 5/16 x 38.75 with 9/16-18 UNF JIC swivel at both ends (H4802 and H4802-6)	2
	48368	50483684	Hose, 5/16 x 68.75 with 9/16-18 UNF JIC swivel at both ends (H4802-1).....	2
40			Snap ring, internal, .461 groove dia.....	1
41			Spool, OC/CC selection.....	1
42*			O-ring, .364 I.D. x .070 (2-012)	1
Repair Kits				
		52057849	Control valve assembly (H4802 and H4802-1 only; includes items 32-37 and 40-42)	
*	40317	50403173	Packing kit (includes items marked with an asterisk)	



4455 Boeing Drive • Rockford, IL 61109-2988 • USA • 815-397-7070
An ISO 9001 Company • Greenlee Textron Inc. is a subsidiary of Textron Inc.

www.greenlee.com

USA Tel: 800-435-0786
Fax: 800-451-2632

Canada Tel: 800-435-0786
Fax: 800-524-2853

International Tel: +1-815-397-7070
Fax: +1-815-397-9247