

INSTRUCTION MANUAL

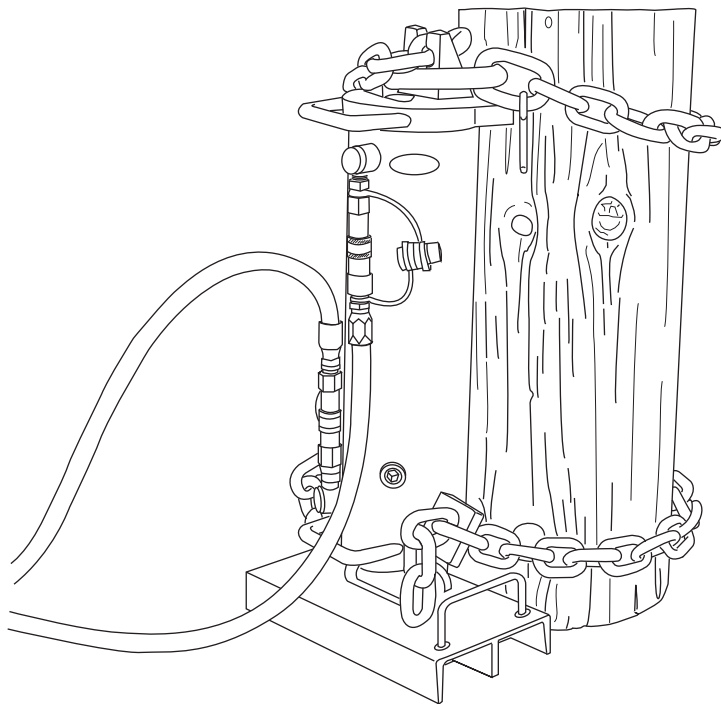

GREENLEE[®]
UTILITY
A Textron Company



H4910A **Pole Puller**



Read and understand all of the instructions and safety information in this manual before operating or servicing this tool.

Register this product at www.greenlee.com

Table of Contents

Description	2
Safety	2
Purpose of this Manual	2
Other Publications	2
Important Safety Information	3-4
Identification	5
Specifications	6-7
Hoses and Fittings	7
Hose Connections	7
Operation	8
Maintenance	9
Troubleshooting	10-11
Disassembly	12
Inspection	13
Assembly	13
Illustrations and Parts Lists	14-15

Description

The Greenlee Utility H4910A Pole Puller is a heavy-duty, portable, hydraulic-powered tool that can be used to pull poles in confined areas, next to buildings, or out in the open.

Featuring built-in carrying handles and proof-certified alloy chains, the pole puller may be used with open-center or closed-center hydraulic systems.

Safety

Safety is essential in the use and maintenance of Greenlee Utility tools and equipment. This manual and any markings on the tool provide information for avoiding hazards and unsafe practices related to the use of this tool. Observe all of the safety information provided.

Purpose of this Manual

This manual is intended to familiarize all personnel with the safe operation and maintenance procedures for the following Greenlee Utility tool:

H4910A (42239) Pole Puller

Keep this manual available to all personnel.

Replacement manuals are available upon request at no charge at www.greenlee.com.

Other Publications

SAE Standard J1273 (Hose and Hose Assemblies):
Publication 99930323

All specifications are nominal and may change as design improvements occur. Greenlee Textron Inc. shall not be liable for damages resulting from misapplication or misuse of its products.

KEEP THIS MANUAL

IMPORTANT SAFETY INFORMATION



SAFETY ALERT SYMBOL

This symbol is used to call your attention to hazards or unsafe practices which could result in an injury or property damage. The signal word, defined below, indicates the severity of the hazard. The message after the signal word provides information for preventing or avoiding the hazard.

⚠ DANGER

Immediate hazards which, if not avoided, **WILL** result in severe injury or death.

⚠ WARNING

Hazards which, if not avoided, **COULD** result in severe injury or death.

⚠ CAUTION

Hazards or unsafe practices which, if not avoided, **MAY** result in injury or property damage.



⚠ WARNING

Pinch points:
Keep hands away from moving parts during operation.

⚠ WARNING

- Support or secure pole that is being removed. An unsecured pole can fall.
- Use only 5/8" alloy chains that have a minimum working load limit of 9071 kg (20,000 lb). Other chains can break during operation.
- Do not change accessories, inspect, adjust, or clean tool when it is connected to a power source. Accidental startup can result in serious injury.

Failure to observe these warnings could result in severe injury or death.

⚠ WARNING



Skin injection hazard:

- Do not use hands to check for leaks.
- Depressurize the hydraulic system before servicing.

Oil under pressure easily punctures skin, causing serious injury, gangrene, or death. If you are injured by escaping oil, seek medical attention immediately.

⚠ WARNING

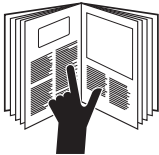

Read and understand all of the instructions and safety information in this manual before operating or servicing this tool.

Failure to observe this warning could result in severe injury or death.

⚠ WARNING



Electric shock hazard:

This tool is not insulated. When using this unit near energized electrical lines, use only certified nonconductive hoses and proper personal protective equipment.

Failure to observe this warning could result in severe injury or death.

⚠ WARNING





Wear eye protection when operating or servicing this tool.

Failure to wear eye protection could result in serious eye injury from flying debris or hydraulic oil.

IMPORTANT SAFETY INFORMATION

	<p style="text-align: center;">⚠ WARNING</p> <p>Wear a hard hat when using this tool.</p> <p>Failure to observe this warning could result in severe injury or death.</p>
---	---

	<p style="text-align: center;">⚠ WARNING</p> <p>Wear hearing protection when using this tool.</p> <p>Long-term exposure to high noise levels could result in hearing loss.</p>
---	---

	<p style="text-align: center;">⚠ WARNING</p> <p>Wear foot protection when using this tool.</p> <p>Failure to observe this warning could result in serious injury.</p>
---	--

	<p style="text-align: center;">⚠ WARNING</p> <p>Tool and other components may be hot during and after operation. Allow to cool before handling, or handle with heat-resistant gloves.</p> <p>Failure to observe this warning could result in severe injury.</p>
---	--

<p>⚠ WARNING</p>
<p>Do not exceed the following hydraulic power source maximums:</p> <ul style="list-style-type: none"> • Hydraulic flow: 56.8 l/min (15 gpm) • Pressure relief: 148.3 bar (2150 psi) • Back pressure: 13.8 bar (200 psi) <p>Failure to observe this warning could result in severe injury or death.</p>

<p>⚠ WARNING</p>
<p>Do not disconnect tool, hoses, or fittings while the power source is running or if the hydraulic fluid is hot. Hot hydraulic fluid can cause serious burns.</p>

<p>⚠ WARNING</p>
<p>Do not reverse hydraulic flow. Operation with hydraulic flow reversed can cause tool malfunction. Connect the pressure (supply) hose and tank (return) hose to the proper ports.</p> <p>Failure to observe this warning could result in severe injury or death.</p>

<p>⚠ CAUTION</p>
<ul style="list-style-type: none"> • Inspect tool before use. Replace any worn, damaged, or missing parts. A damaged or improperly assembled tool can malfunction, injuring nearby personnel. • Inspect the hydraulic hoses and couplers every operating day. Repair or replace if leakage, cracking, wear, or damage is evident. Damaged hoses or couplers can fail, resulting in injury or property damage. • Use this tool for manufacturer's intended purpose only. Use other than that which is described in this manual can result in injury or property damage. • Make sure that all bystanders are clear of the work area when operating the tool. Nearby personnel can be injured by flying debris. <p>Failure to observe these precautions may result in injury.</p>

<p>IMPORTANT</p>
<p>Procedure for connecting or disconnecting hydraulic hoses, fittings, or components:</p> <ol style="list-style-type: none"> 1. Move the flow lever on the hydraulic power source to the off position. 2. Stop the hydraulic power source. 3. Follow the sequence under "Hose Connections" to prevent pressure buildup. In case some pressure has built up, loosen hoses, fittings, or components slowly.

Note: Keep all decals clean and legible, and replace when necessary.

Identification

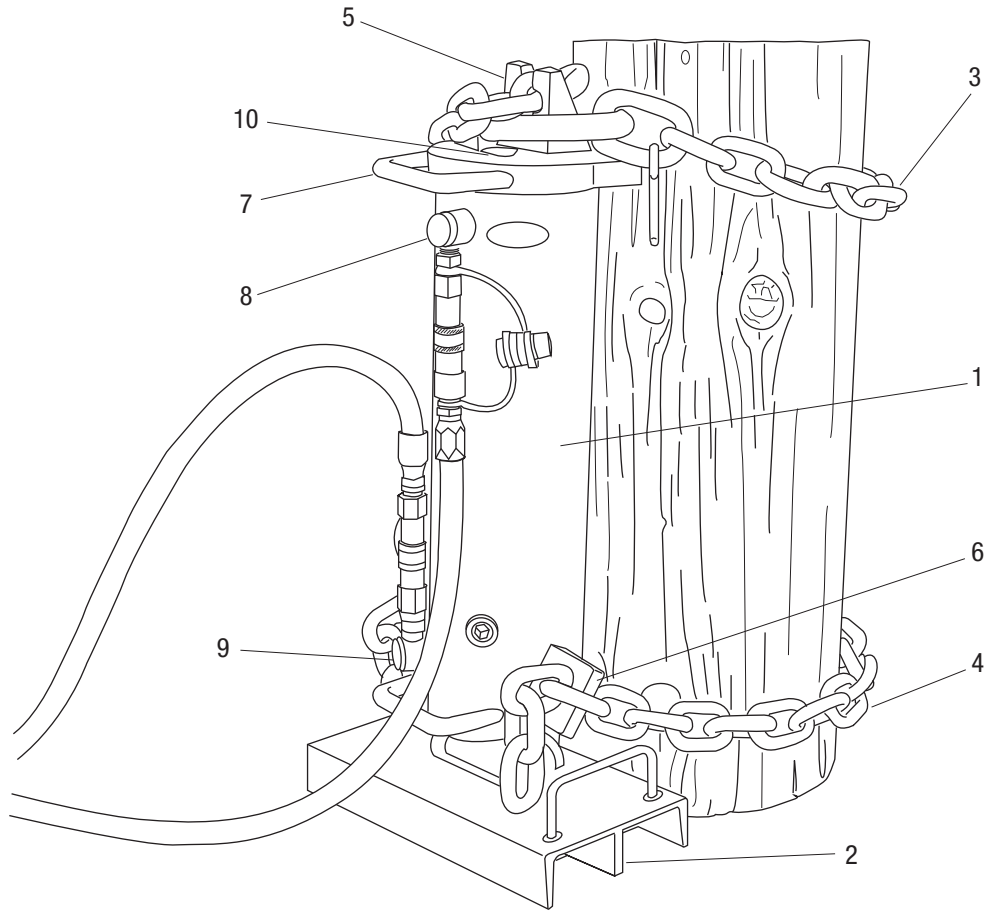

Pole Puller

- | | |
|--------------------|---------------------|
| 1. Cylinder | 6. Lower Chain Lugs |
| 2. Base | 7. Handles |
| 3. Upper Chain | 8. Pressure Port P |
| 4. Lower Chain | 9. Return Port T |
| 5. Upper Chain Lug | 10. Serial Number |

Specifications

Pole Puller

Type of Hydraulic System.....Open-center or closed-center

Hydraulic Ports

Pressure 1/2 female NPT

Return 1/2 female NPT

Lift Capacity56,000 lb @ 2000 psi

Stroke42.5 cm (16.8")

Mass/Weight

Cylinder Only..... 41.7 kg (92.0 lb)

Chains and Base..... 63.5 kg (140.0 lb)

Width (with base).....38.0 cm (15.0")

Height (with base)

Retracted80.0 cm (31.5")

Extended.....115.0 cm (45.3")

Chains

⚠ WARNING

Use only 5/8" alloy chains that have a minimum working load limit of 9071 kg (20,000 lb). Other chains can break during operation.

Failure to observe this warning could result in severe injury or death.

Chains are furnished with the tool. Replacement chains are available from Greenlee Utility as repair parts. Contact an authorized Greenlee Utility service center. Any chain used with this tool must meet the following requirements:

Chain—alloy1.6 cm (5/8")

Minimum Working Load Limit..... 9071 kg (20,000 lb)

Hydraulic Power Source

⚠ WARNING

Do not exceed the following hydraulic power source maximums:

- Hydraulic flow: 56.8 l/min (15 gpm)
- Pressure relief: 148.3 bar (2150 psi)
- Back pressure: 13.8 bar (200 psi)

Failure to observe this warning could result in severe injury or death.

Type of Hydraulic System.....Open-center or closed-center

Flow

Minimum 15.1 l/min (4 gpm)

Recommended..... 26.5 l/min (7 gpm)

Maximum 56.8 l/min (15 gpm)

Operating Pressure

Minimum 20.7 bar (300 psi)

Maximum 138 bar (2000 psi)

Reservoir Capacity (minimum) 18.9 l (5 gal)

Filtration.....10 micron (nominal)

Pressure Relief Setting 148.3 bar (2150 psi)

Back Pressure (maximum)* 13.8 bar (200 psi)

* 13.8 bar (200 psi) is the maximum agreed standard back pressure for the HTMA (Hydraulic Tool Manufacturers Association). Greenlee Utility tools will operate satisfactorily at this standard.

1. Maximum hydraulic fluid temperature must not exceed 60 °C (140 °F). A sufficient oil cooling capacity is needed to limit the hydraulic fluid temperature.
2. Hydraulic flow must not exceed 56.8 l/min (15 gpm). Install a flow meter in the return line to measure the rate of hydraulic flow before using the tool.
3. Pressure relief valve setting must not exceed 14.8 bar (2150 psi) at the tool's maximum flow. Locate the pressure relief valve in the supply circuit to limit excessive hydraulic pressure to the tool.

Specifications (cont'd)

Hydraulic Schematic

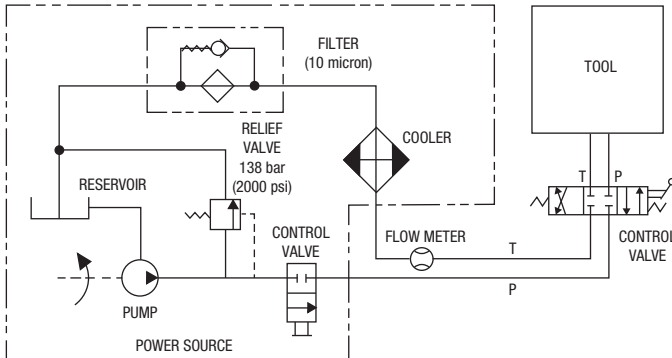

Recommended Hydraulic Fluids

	<h2>⚠ WARNING</h2>
	<p>Electric shock hazard:</p> <p>When using this unit near energized electrical lines, select and maintain the hydraulic fluid to meet the minimum dielectric standards required by your safety department.</p> <p>Failure to observe this warning could result in severe injury or death.</p>

Use any non-detergent, petroleum-based hydraulic fluid which meets the following specifications or HTMA specifications.

S.U.S. @

38 °C (100 °F).....	140 to 225
99 °C (210 °F).....	40 minimum
Flash Point.....	170 °C (340 °F) minimum
Pour Point.....	-34 °C (-30 °F) minimum

Hoses and Fittings

Installation and Maintenance

Refer to publication 99930323, SAE J1273 (Hose and Hose Assemblies).

Replacement

Refer to a Greenlee Utility catalog or publication 99910322, Low Pressure Quick Couplers, Adapters, and Hoses.

<h2>⚠ WARNING</h2>
<p>Do not disconnect tool, hoses, or fittings while the power source is running or if the hydraulic fluid is hot. Hot hydraulic fluid can cause serious burns.</p>

Hose Connections

Control Valve

Refer to the Hydraulic Schematic under “Specifications.”

A three-position, four-way, directional control valve must be between the power source and tool. Verify that valve type, flow, and pressure rating is compatible with power source specifications.

Connecting Hoses

1. Move the flow lever on the hydraulic power source to the off position.
2. Stop the hydraulic power source.
3. Connect the return (tank) hose from the control valve (port T) to the tool (port T).
Note: Return (tank) hose should always be connected before pressure (supply) hose connection to prevent pressure buildup inside the tool.
4. Connect the supply (pressure) hose from the control valve (port P) to the tool (port P).

Disconnecting Hoses

1. Move the flow lever on the hydraulic power source to the off position.
2. Stop the hydraulic power source.
3. Disconnect the supply (pressure) hose from the control valve (port P) to the tool (port P).
Note: Supply (pressure) hose should always be disconnected before return (tank) hose disconnection to prevent pressure buildup inside the tool.
4. Disconnect the return (tank) hose from the control valve port (port T) to the tool (port T).
5. Install dust caps over the ports to prevent contamination.

Operation

	⚠ WARNING
	<p>Electric shock hazard:</p> <p>This tool is not insulated. When using this unit near energized electrical lines, use only certified nonconductive hoses and proper personal protective equipment.</p> <p>Failure to observe this warning could result in severe injury or death.</p>

	⚠ WARNING
	<p>Pinch points:</p> <p>Keep hands away from moving parts during operation.</p>

⚠ WARNING
<p>Do not disconnect tool, hoses, or fittings while the power source is running or if the hydraulic fluid is hot. Hot hydraulic fluid can cause serious burns.</p>

⚠ WARNING
<ul style="list-style-type: none"> • Support or secure pole that is being removed. An unsecured pole can fall. • Use only 5/8" alloy chains that have a minimum working load limit of 9071 kg (20,000 lb). Other chains can break during operation. • Do not change accessories, inspect, adjust, or clean tool when it is connected to a power source. Accidental startup can result in serious injury. <p>Failure to observe these warnings could result in severe injury or death.</p>

Pre-Operation

Refer to the "Identification" section and the Hydraulic Schematic under "Specifications."

1. Stop the power source.
2. Connect hydraulic hoses from control valve to pole puller. Refer to "Hose Connections." Start power source.
3. It is recommended that power source be allowed to run (idle) for a few minutes to warm hydraulic reservoir fluid. Actuating tool intermittently will reduce the time required to warm fluid to an efficient operating temperature.
4. Cycle tool full stroke to remove any trapped air from tool and hoses. Stop power source. Check hydraulic fluid level in power source reservoir.

Operation

Refer to the "Identification" section.

1. Pole that is to be removed must be supported or secured before and while pulling pole from ground.
2. Place pole puller base (2) next to pole that is to be pulled, preferably on level ground. Set pole puller cylinder (1) on base.
3. Attach upper chain (3) by placing large loop over upper chain lug (5) of pole cylinder (1). Loop chain around pole and hook chain into upper lug. Allow some chain slack to permit puller to slide down pole after it completes pulling stroke.
4. Attach lower chain (4) by hooking one end of chain into one lower chain lug (6), looping chain around pole and hooking chain into opposite lower chain lug (6).
5. Start power source, and actuate pole puller as many times as necessary to remove pole.

Note: Chains may need to be adjusted as pole diameter increases. Stop power source before adjusting chains.
6. Stop power source. Remove upper and lower chains from pole.

Maintenance

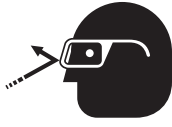
	⚠ WARNING
	<p>Wear eye protection when operating or servicing this tool.</p> <p>Failure to wear eye protection could result in serious eye injury from flying debris or hydraulic oil.</p>

⚠ WARNING
<p>Do not change accessories, inspect, adjust, or clean tool when it is connected to a power source. Accidental startup can result in serious injury.</p> <p>Failure to observe this warning could result in severe injury or death.</p>

⚠ CAUTION
<p>Inspect the hydraulic hoses and couplers every operating day. Repair or replace if leakage, cracking, wear, or damage is evident. Damaged hoses or couplers can fail, resulting in injury or property damage.</p>

Use this maintenance schedule to maximize the tool's service life.

Notes: Keep all decals clean and legible, and replace when necessary.

When disposing of any components (hydraulic hoses, hydraulic fluid, worn parts, etc.), do so in accordance with federal, state, and local laws or ordinances.

Daily

1. Wipe all tool surfaces clean.
2. Inspect the tool for signs of leaks, cracks, wear, or damage. Repair or replace components if necessary.
3. Inspect the hydraulic hoses and fittings for signs of leaks, cracks, wear, or damage. Replace if necessary.
4. Install dust caps over the hydraulic ports when the tool is disconnected.

Monthly

Perform a thorough inspection of the hydraulic hoses and fittings as described in publication 99930323, SAE J1273 (Hose and Hose Assemblies).

Annually

Some organizations require an annual inspection. Have the tool inspected by an authorized Greenlee Utility service center.

Troubleshooting

Before You Begin

1. Tool must be connected to the correct power source system. Refer to “Specifications” for type of hydraulic system required. Verify the power source hydraulic system.
2. Verify that pressure and return hydraulic hoses are connected properly to the tool and power source ports.
3. Power source reservoir must be filled to FULL level with hydraulic fluid.
4. Start the power source. All power source shut-off devices must be engaged or opened (clutch engaged, separate ON/OFF valves open, etc.).
5. After verifying all of the above, check the tool to see if it operates.

If the tool does not operate, it will be necessary to pinpoint the tool, hoses, or power source as the problem area. The following steps will help to determine the problem area.

Determining the Problem Area

1. Check power source flow and pressure if the proper gauges and tools are available. If these items are not available, proceed to Step 2.
2. Stop power source. Disconnect existing tool from the hydraulic hoses and power source.
3. Connect a known working tool to the hoses and power source. See the tool’s operator’s manual for correct hook-up procedure. Start the power source.
 - If the known working tool operates, the problem is in the disconnected tool. Refer to the Troubleshooting chart in this manual.
 - If the known working tool does not operate, the problem is likely to be in the hoses or the power source. Proceed to Step 4.
4. Stop the power source. Disconnect the existing hydraulic hoses from the known working tool and power source.
5. Connect a different set of hoses to the known working tool and power source. Start the power source.
 - If the known working tool operates with the different set of hydraulic hoses, the problem is in the disconnected hoses.
 - If the known working tool does not operate, the problem is in the power source. Refer to your power source operator’s manual for troubleshooting.

Troubleshooting (cont'd)

Problem	Probable Cause	Probable Remedy
Tool does not operate.	No hydraulic fluid in system or fluid level low.	Check fluid level. Fill to FULL mark. Check system for leaks.
	Another valve in system has stopped or redirected flow.	Check for another valve between power source and control valve. Place valve in flow ON position.
	Tool components worn or damaged.	Disassemble tool. Replace worn or damaged components.
Tool operates erratically.	Hydraulic fluid cold.	Viscosity of fluid may be too high at start of tool operation. Allow fluid to warm to the operating temperature. Actuate the tool intermittently to reduce the warming time.
	Air in system.	Check pump suction line for damage or loose clamps. Tighten clamps or replace components if necessary. Fill reservoir.
	Tool components sticking or binding.	Check for worn or damaged components. Replace components.
Tool operates slowly.	Power source components not adjusted correctly.	Refer to the power source manufacturer's manual for recommended speed, flow, and pressure settings.
	Hydraulic fluid cold.	Viscosity of fluid may be too high at start of tool operation. Allow fluid to warm to the operating temperature. Actuate the tool intermittently to reduce the warming time.
	Hydraulic fluid level low.	Check fluid level. Fill to FULL mark. Check system for leaks.
	Tool components worn or damaged.	Disassemble tool. Replace worn or damaged components.
Tool leaks hydraulic fluid.	Hydraulic fittings loose.	Tighten fittings.
	Worn or damaged seals.	Replace worn or damaged seals.
	Tool components worn or damaged.	Disassemble tool. Replace worn or damaged components.
Tool operates backwards.	Hydraulic flow reversed to tool.	Reverse flow to tool. Check for valve in system that has reversed flow. Check hoses for proper flow.
	Hydraulic pressure and return lines connected to opposite tool ports.	Disconnect hoses. Reverse couplers. Reconnect hoses to proper tool ports.

Disassembly

Complete disassembly of the tool is not recommended. If a complete overhaul is necessary, return the tool to your nearest authorized Greenlee Utility distributor or to Greenlee.

	<h3>⚠ WARNING</h3>
	<p>Skin injection hazard:</p> <ul style="list-style-type: none"> • Do not use hands to check for leaks. • Depressurize the hydraulic system before servicing. <p>Oil under pressure easily punctures skin, causing serious injury, gangrene, or death. If you are injured by escaping oil, seek medical attention immediately.</p>

<h3>⚠ WARNING</h3>
<p>Do not disconnect tool, hoses, or fittings while the power source is running or if the hydraulic fluid is hot. Hot hydraulic fluid can cause serious burns.</p>

<h3>IMPORTANT</h3>
<p>Procedure for connecting or disconnecting hydraulic hoses, fittings, or components:</p> <ol style="list-style-type: none"> 1. Move the flow lever on the hydraulic power source to the off position. 2. Stop the hydraulic power source. 3. Follow the sequence under "Hose Connections" to prevent pressure buildup. In case some pressure has built up, loosen hoses, fittings, or components slowly.

Complete disassembly of the tool is seldom necessary. Disassemble only the area(s) necessary to correct the problem. Refer to the Illustrations and Parts Lists for identification of parts as they are removed.

Disassembly should be done on a flat, clean surface. Some parts may fall free during disassembly. To prevent part loss or damage, keep the tool as close to the working surface as possible.

Inspect all parts as they are disassembled and mating parts in the tool that are not removed for signs of damage, wear, cracks, etc. Replace any parts which appear to be damaged.

When removing seals which must slide over sharp surfaces, be careful not to damage the seals. Use a rolling motion and apply hydraulic fluid to ease removal of O-rings if necessary.

H4910A Pole Puller (138578 Cylinder)

1. Remove square retaining ring (14). A spanner wrench with 1/4" lugs will aid in disassembly. Place spanner wrench in two 1/4" holes in gland (3), and rotate gland clockwise until retaining ring has been removed from slot in cap and tube assembly (1). Remove gland, piston, and cylinder rod (3, 4, 2) from cap and 8-tube assembly (1).
2. Remove the 1-1/2"-12 locknut (6) from cylinder rod (2), and remove piston (4).
3. Remove bearing ring (7), Teflon seal (8), and O-rings (9, 10) from piston (4).
4. Remove relief valve (5) from piston (4). The relief valve should not be disassembled. If defective, it should be replaced as a component.
5. Slide gland (3) off cylinder rod (2). Remove U-cup (13) and rod wiper (15) from bore of gland. Remove O-ring (11) and backup washer (12) from gland.

Inspection

1. Cap and Tube Assembly (1): Bore must be smooth and free of grooves, nicks, and cracks. If not, replace the component.
2. Cylinder Rod (2): All surfaces must be smooth and free of grooves, nicks, and cracks; threads must be free of damage. If not, replace the component.
3. Gland (3): All surfaces must be smooth and free of grooves, nicks, and cracks. If not, replace the component.
4. Piston (4): All surfaces must be smooth and free of grooves, nicks, and cracks. If not, replace the component.
5. Relief Valve (5): If relief valve is inoperative and/or threads are damaged, it should be replaced as a component.
6. Locknut (6): Check for damaged threads. If damaged, replace locknut.
7. O-rings and Seals: Always replace O-rings and seals in components that have been disassembled with new O-rings and seals during assembly. A packing kit is available that includes all O-rings and seals.

Assembly

When assembling parts, refer to the Illustrations and Parts Lists for correct orientation and placement of parts.

Clean all parts with solvent, taking care to protect eyes, and then dry thoroughly. Do not expose O-rings or other packing components to solvent for long periods of time.

Inspect all parts as they are assembled for signs of damage, wear, cracks, etc. Do not install any parts which appear to be damaged.

Apply hydraulic fluid or O-ring lubricant to all O-rings and all metal surfaces which O-rings must slide over. When installing an O-ring over a sharp edge, use a rolling action to avoid damage to the O-ring.

Wherever assembled parts cause metal-to-metal contact, coat the surfaces with hydraulic fluid or O-ring lubricant.

H4910A Pole Puller (138578 Cylinder)

1. Install U-cup (13) and rod wiper (15) into bore of gland (3). Install O-ring (11) and backup washer (12) onto gland. Slide gland (3) onto cylinder rod (2).
2. Install relief valve (5) on piston (4).
3. Install bearing ring (7), O-ring (9), Teflon seal (8), and O-ring (10) on piston (4).
4. Install piston (4) on cylinder rod (2). Thread 1-1/2"-12 locknut (6) on cylinder rod. Torque locknut to 880 ± 40 ft-lb.
5. Install gland, piston, and cylinder rod (3, 4, 2) into cap and tube assembly (1). Install hook end of square retaining ring (14) through slot in cap and tube assembly and into hold in gland. Using a spanner wrench, rotate gland counterclockwise, pulling retaining ring fully into the groove in cylinder assembly.

Illustration and Parts List—H4910A Pole Puller

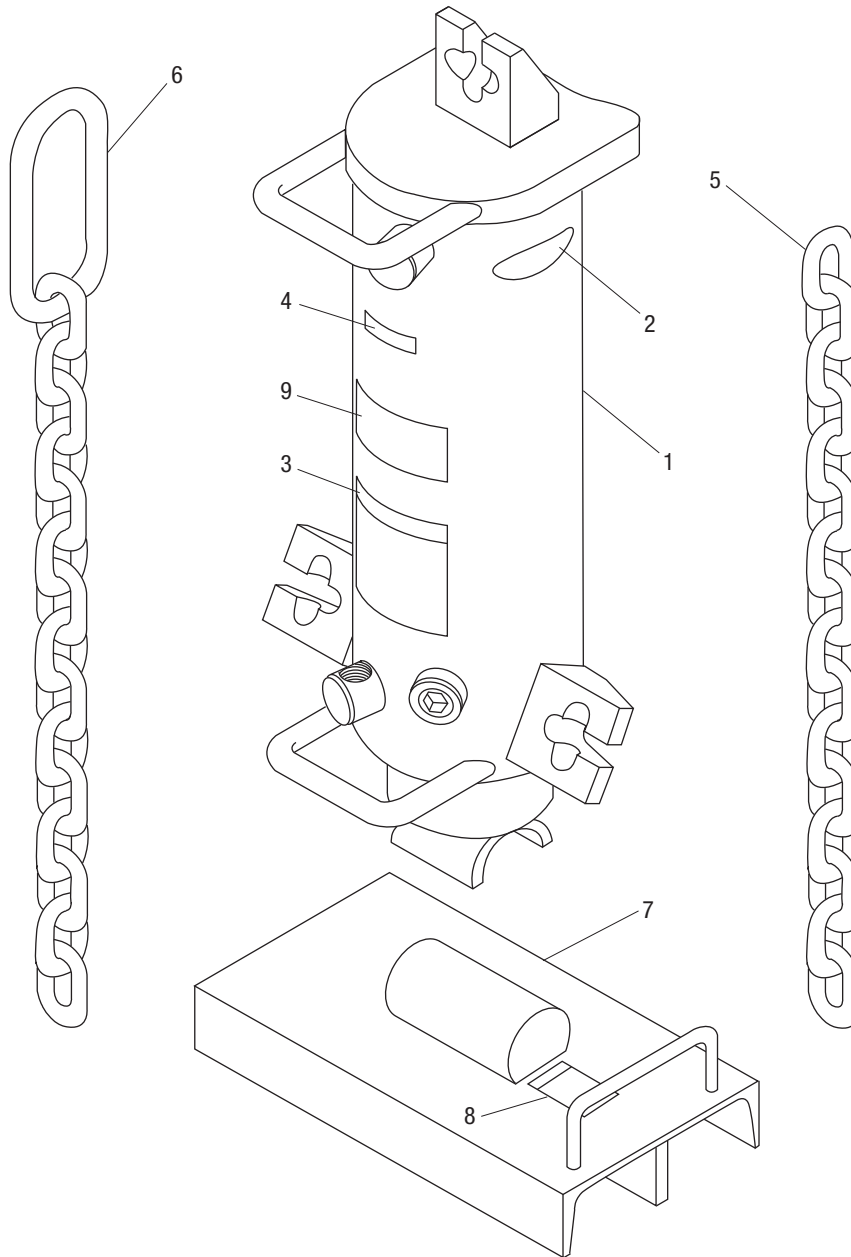

Key	UPC No. 78-3310-	Part No.	Description	Qty
1	44058	50440586	Cylinder (refer to separate breakdown).....	1
2	41547	50415471	Decal, Greenlee Utility	1
3	44059	50440594	Decal, "Caution – Be Sure of Footing"	1
4	44060	52001964	Decal, pressure/flow/weight	1
5	40517	50405172	Lower chain	1
6	40282	50402822	Upper chain	1
7	40283	50402832	Base plate.....	1
8	40917	50409121	Decal, "Caution – Keep Away from Pinch Points".....	1
9		52001963	Decal, Safety.....	1

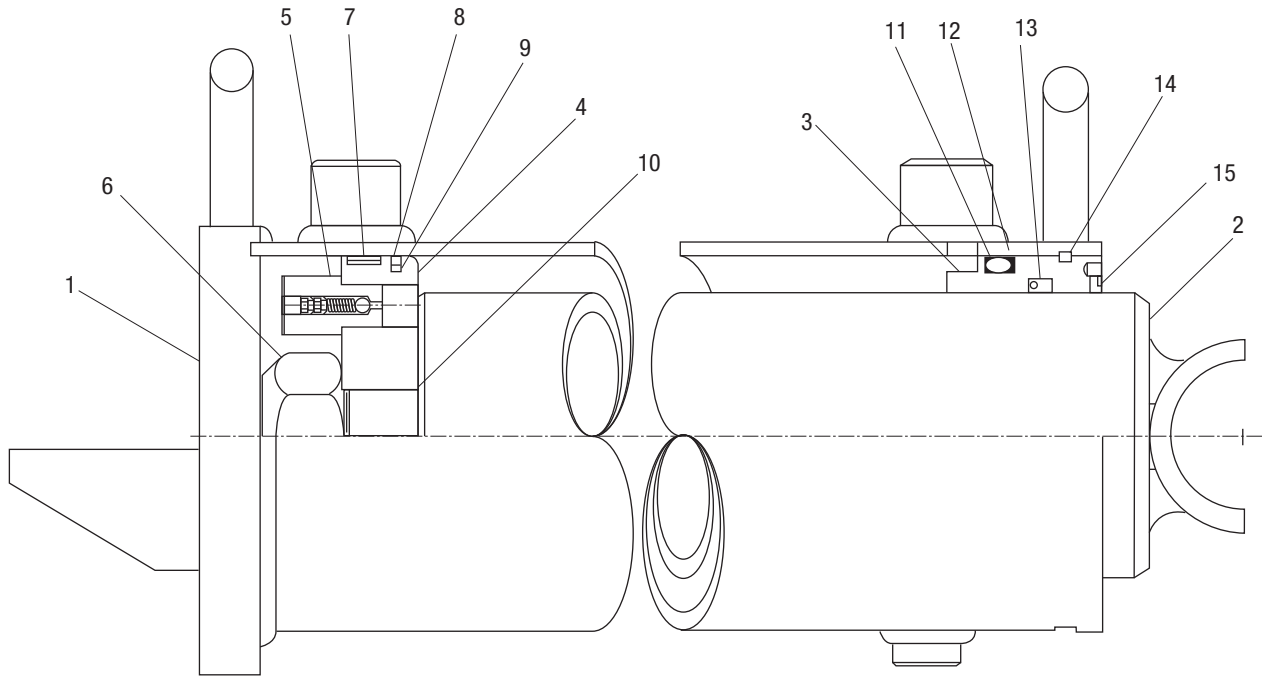
Illustration and Parts List—138578 Cylinder

Key	UPC No. 78-3310-	Part No.	Description	Qty
1	48917		Cap and tube assembly.....	1
2	48918	50489186	Cylinder rod	1
3	48919	50489194	Gland	1
4	48921	52001362	Piston.....	1
5	43447	50434470	Relief valve.....	1
6	54920	90549201	Locknut, 1-1/2"-12	1
7*			Bearing ring.....	1
8*			Teflon seal	1
9*			O-ring.....	1
10*			O-ring.....	1
11*			O-ring.....	1
12*			Backup washer	1
13*			U-cup.....	1
14*			Square retaining ring.....	1
15*			Rod wiper.....	1
*	42064	50420642	Packing kit (includes items marked with an asterisk).....	1



GREENLEE®

A Textron Company

USA	800-435-0786	Fax:	800-451-2632
	815-397-7070	Fax:	815-397-1865
Canada	800-435-0786	Fax:	800-524-2853
International	+1-815-397-7070	Fax:	+1-815-397-9247

4455 Boeing Drive • Rockford, IL 61109-2988 • USA • 815-397-7070
An ISO 9001 Company • Greenlee Textron Inc. is a subsidiary of Textron Inc.

www.greenlee.com